

SEMI-AUTOMATIC SHEETERS MAN TRONIC

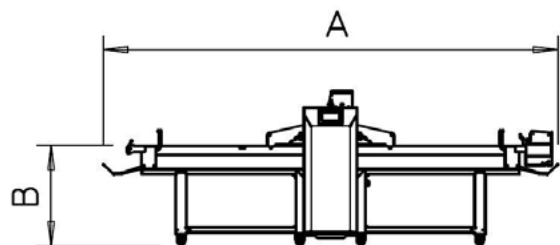

- Heavy duty steel stove painted structure (optional INOX)
- Standard colour: grey RAL 9007
- Mounted on the same frame and mechanical of the bigger fully automatic sister, the QMT sheeter offer a great reliability and absolutely lamination precision
- The belts inversion happen through a practical balancer or through a pedal board
- The lamination programming is entire managed through the 5" touch screen with the possibility of memorize till 100 recipes
- The opening and closing cylinders system made through two screws in bain of oil assure an high precisions lamination till one tenth of millimeter also with stiff dough
- Frontal and back covers made in steel stove painted (no plastic parts) assembled from the top and fixed with screws avoid that the flour enter inside the mechanical parts of the machine and damage them
- Very noiseless thanks to the trapezoidal and toothed belts transmission
- Optional: automatic flour duster and coiler



MAN TRONIC 1600 - 1800

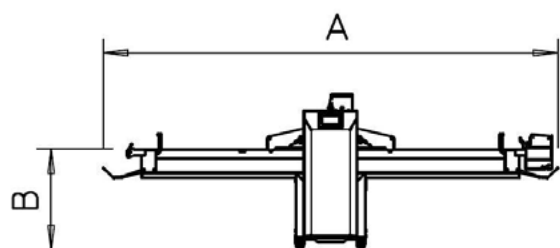

MAN TRONIC 1200 - 1400

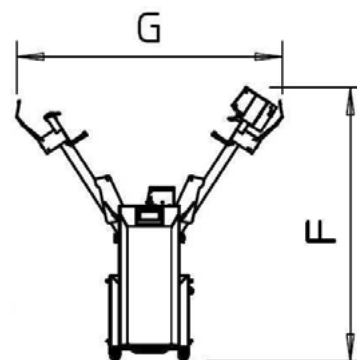
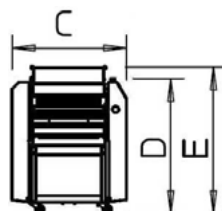

	Belts dimensions	Speed	Cylinder opening	Power	Voltage	Dimensions							Weight	
						mm								Kg
						A	B	C	D	E	F	G		
TRONIC PLUS TRONIC MAN TRONIC	654/2000	10÷60	0÷60	2,1	400/3~/50	4530	870	1045	1230	1340	2690	2850	370	
	654/1800	10÷60	0÷60	2,1	400/3~/50	4130	870	1045	1230	1340	2530	2630	370	
	654/1600	10÷60	0÷60	2,1	400/3~/50	3730	870	1045	1230	1340	2360	2405	370	
	654/1400	10÷60	0÷60	2,1	400/3~/50	3330	870	1045	1230	1340	2190	2185	370	
	654/1200	10÷60	0÷60	2,1	400/3~/50	2930	870	1045	1230	1340	2025	1965	370	
Q670	654/2000	35	0÷60	1,5	400/3~/50	4530	870	1170	1340	-	-	-	270	
	654/1800	35	0÷60	1,5	400/3~/50	4130	870	1170	1340	2530	2630	-	270	
	654/1600	35	0÷60	1,5	400/3~/50	3730	870	1170	1340	2360	2405	-	270	
	654/1400	35	0÷60	1,5	400/3~/50	3330	870	1170	1230	2190	2185	-	270	
	654/1200	35	0÷60	1,5	400/3~/50	2930	870	1170	1230	2025	1965	-	270	
Q600	584/1500	35	0÷50	0,75	400/3~/50	3485	870	1050	1250	2250	1205	-	190	
	584/1400	35	0÷50	0,75	400/3~/50	3285	870	1050	1250	2150	1140	-	190	
	584/1300	35	0÷50	0,75	400/3~/50	3085	870	1050	1250	2060	1075	-	190	
	584/1200	35	0÷50	0,75	400/3~/50	2885	870	1050	1250	1965	1010	-	190	
	584/1000	35	0÷50	0,75	400/3~/50	2485	870	1050	1250	1775	880	-	190	
Q500	488/1200	35	0÷40	0,55	400/3~/50	2855	850	865	1315	1960	800	-	160	
	488/1000	35	0÷40	0,55	400/3~/50	2455	850	865	1315	1765	720	-	160	
	488/900	35	0÷40	0,55	400/3~/50	2255	850	865	1315	1665	680	-	160	
	488/800	35	0÷40	0,55	400/3~/50	2055	850	865	1315	1565	645	-	160	
	488/700	35	0÷40	0,55	400/3~/50	1855	850	865	1315	1470	605	-	160	
Q50S	488/800	35	0÷40	0,55	400/3~/50	2055	850	865	1315	1550	775	-	115	
	488/700	35	0÷40	0,55	400/3~/50	1855	850	865	1315	1455	720	-	115	
Q50B	488/800	35	0÷40	0,55	400/3~/50	1700	165	865	630	845	785	-	115	
	488/700	35	0÷40	0,55	400/3~/50	1500	165	865	630	750	785	-	115	