

MANUAL SHEETER QUEEN 600

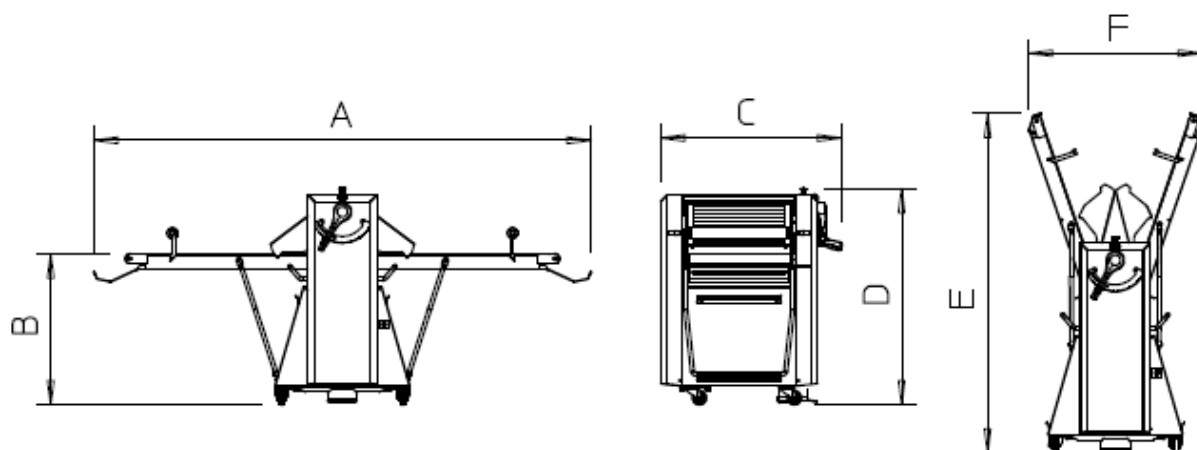

- Heavy duty steel stove painted structure (optional INOX)
- Standard colour: grey RAL 9007
- Clean lines and manufacture solidity make this machine the perfect allied for whatever laboratory
- Mounted on rubber castors with brakes to increase the stability, utilize all the motor and generous cylinders power thanks to a strong trapezoidal and chains transmission
- Frontal and back covers made in steel stove painted (no plastic parts) assembled from the top and fixed with screws avoid that the flour enter inside the mechanical parts of the machine and damage them
- Foldable and removable tables
- Double controls (by hand with a very precise balancer and by foot)
- Under tables with collection flour tray made in stainless steel
- Ergonomic handle with tempered fixing tooth that avoid the usury



	Belts dimensions	Speed	Cylinder opening	Power	Voltage	Dimensions							Weight
						mm	m/min.	mm	kW	V~/Hz	mm		
						A	B	C	D	E	F	G	
TRONIC PLUS TRONIC MAN TRONIC	654/2000	10÷60	0÷60	2,1	400/3~/50	4530	870	1045	1230	1340	2690	2850	370
	654/1800	10÷60	0÷60	2,1	400/3~/50	4130	870	1045	1230	1340	2530	2630	370
	654/1600	10÷60	0÷60	2,1	400/3~/50	3730	870	1045	1230	1340	2360	2405	370
	654/1400	10÷60	0÷60	2,1	400/3~/50	3330	870	1045	1230	1340	2190	2185	370
	654/1200	10÷60	0÷60	2,1	400/3~/50	2930	870	1045	1230	1340	2025	1965	370
Q670	654/2000	35	0÷60	1,5	400/3~/50	4530	870	1170	1340	-	-		270
	654/1800	35	0÷60	1,5	400/3~/50	4130	870	1170	1340	2530	2630		270
	654/1600	35	0÷60	1,5	400/3~/50	3730	870	1170	1340	2360	2405		270
	654/1400	35	0÷60	1,5	400/3~/50	3330	870	1170	1230	2190	2185		270
	654/1200	35	0÷60	1,5	400/3~/50	2930	870	1170	1230	2025	1965		270
Q600	584/1500	35	0÷50	0,75	400/3~/50	3485	870	1050	1250	2250	1205		190
	584/1400	35	0÷50	0,75	400/3~/50	3285	870	1050	1250	2150	1140		190
	584/1300	35	0÷50	0,75	400/3~/50	3085	870	1050	1250	2060	1075		190
	584/1200	35	0÷50	0,75	400/3~/50	2885	870	1050	1250	1965	1010		190
	584/1000	35	0÷50	0,75	400/3~/50	2485	870	1050	1250	1775	880		190
Q500	488/1200	35	0÷40	0,55	400/3~/50	2855	850	865	1315	1960	800		160
	488/1000	35	0÷40	0,55	400/3~/50	2455	850	865	1315	1765	720		160
	488/900	35	0÷40	0,55	400/3~/50	2255	850	865	1315	1665	680		160
	488/800	35	0÷40	0,55	400/3~/50	2055	850	865	1315	1565	645		160
	488/700	35	0÷40	0,55	400/3~/50	1855	850	865	1315	1470	605		160
Q50S	488/800	35	0÷40	0,55	400/3~/50	2055	850	865	1315	1550	775		115
	488/700	35	0÷40	0,55	400/3~/50	1855	850	865	1315	1455	720		115
Q50B	488/800	35	0÷40	0,55	400/3~/50	1700	165	865	630	845	785		115
	488/700	35	0÷40	0,55	400/3~/50	1500	165	865	630	750	785		115